



# GAS PIPE SIZING SUBMITTAL REQUIREMENTS

---

A permit is required for new and replacement gas pipes and is required prior to installation. Following is a list of requirements based on the City of East Palo Alto Adopted Codes. Please contact the Building Services Division for any questions or additional information.

## **GENERAL REQUIREMENTS:**

All work exceeding \$1,000 requires the installation of listed/approved *smoke alarms* and *carbon monoxide alarms*.

**Smoke Alarms:** Must be installed:

- a) In each room used for sleeping purposes.
- b) In each hallway outside of the sleeping room(s).
- c) On each level of the dwelling, including basements.

**Carbon Monoxide Alarms** must be installed in dwellings which contain a fuel fire appliance:

- a) Outside of each sleeping room in the immediate vicinity of the bedroom(s).
- b) On each level of the dwelling, including basements.
- c) Where a fuel burning appliance is at or near a bedroom, a CO alarm will be installed in the bedroom.

## **SUBMIT:**

One (1) properly completed building permit application.

Three (3) sets of legible building plans (1/4"-1' scale, 18"X24 size or 11" X 17").

Two (2) copies of equipment specifications.

## **PLANS SHALL CONSIST OF:**

### **Cover Sheet Showing:**

- Project address.
- Project Scope
- Note on plan: Project to comply with the 2022 CBC, 2022 CEC, 2022 CMC, 2022 CPC, 2022 CA Energy Code, 2022 CA Green Building Standards Code, and City of East Palo Alto Municipal Code.

### **Show on Plan:**

- Size and length of each section of pipe, both existing (E) and new (N). Please count vertical and horizontal distance.
- All appliances, existing (E) and new (N) that will be connected to the gas line. Label each appliance and the Btu rating (*see example illustration below*).
- If the new gas line will connect directly to the existing (E) meter or at a point along the existing line creating a new branch. If the line is connected directly to the existing meter, you need to show only the new piping on your drawing.

**GENERAL CODE REQUIREMENTS:**

**Testing Requirements:**

- Test new gas pipe at 10 psi minimum for 15 minutes.
- Mechanical gauges used to measure test pressure shall not exceed 15lbs. psi.
- Exceptions: Illuminating gas appliances for installation in vented fireplaces, gas fireplaces, and outdoor grills shall not be required to have sediment traps.
- Required sediment traps (3-inch min. length) shall be installed as close to the inlet of the equipment.

**EXAMPLE ILLUSTRATION**

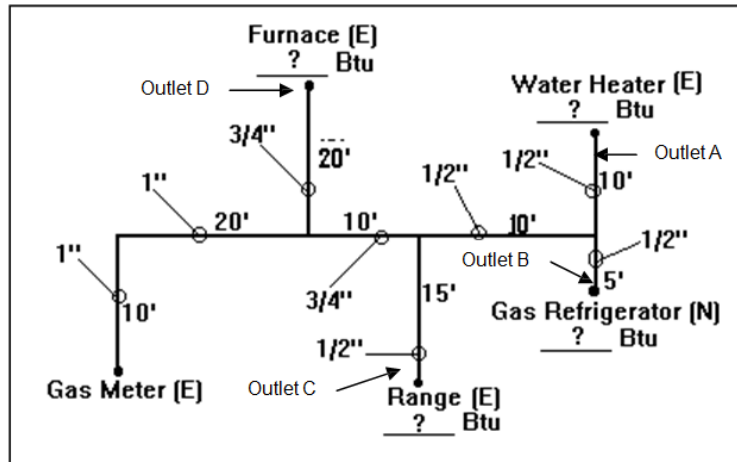

**Example Problem:** Determine the required pipe size of each section and outlet of the piping system shown in Figure 1. Gas to be used has a specific gravity of sixty-hundredths (0.60) and eleven hundred (1100) Btu per cubic foot (11.4 W/L), delivered at eight (8) inch (203.2mm) water column pressure.

**Note:** to determine cubic feet of gas per hour divide the BTU rating by 1100.

**Solution:**

- 1) Maximum gas demand of OUTLET A – 32 cubic feet per hour (0.21 L/sec) (from Table 12-1)  
 Maximum gas demand of OUTLET B – 3 cubic feet per hour (0.02 L/sec) (from Table 12-1)  
 Maximum gas demand of OUTLET C – 59 cubic feet per hour (0.46 L/sec) (from Table 12-1)  
 Maximum gas demand of OUTLET D – 136 Cubic feet per hour (1.1 L/sec) (150,000 Btu/hr (43,950 W/hr) divided by 1100 Btu per cubic foot (11.4 W/L))
- 2) The length of pipe from the gas meter to the most remote outlet (OUTLET A) is 60 feet (18.2 m)
- 3) Using the column marked 60 feet (18.2 m) in Table 12-8:  
**OUTLET A**, supplying 32 cubic feet per hour 0.21 L/sec), requires one-half (1/2) inch (12.7 mm) pipe. Section 1 supplying  
**OUTLETS A & B**, or 35 cubic feet per hour (0.24 L/sec) requires one-half (1/2) inch (12.7 mm) pipe. Section 2, supplying  
**OUTLETS A, B, and C**, or 94 cubic feet per hour (0.7 L/sec) requires three-quarter (3/4) inch (19.2 mm) pipe. Section 3, supplying  
**OUTLETS A, B, C & D**, or 230 cubic feet per hour (1.8 L/sec), requires one (1) inch (25.4 mm) pipe.
- 4) Using the column marked 60 feet (18.2 m) in Table 12-3 (no column for actual length of 55 feet (16.7 m):  
**OUTLET B**, supplying 3 cubic feet per hour (0.02 L/sec.), requires one-half (1/2) inch (12.7 mm) pipe.  
**OUTLET C**, supplying 59 cubic feet per hour (0.46 L/sec.), requires one-half (1/2) inch (12.7 mm) pipe.
- 5) Using the column marked 50 feet (15.2 m) in Table 12-3:  
**OUTLET D**, supplying 136 cubic feet per hour (1.1 L/sec), requires three-quarter (3/4) inch (19.1 mm) pipe.

**Table 12-1:** (Approximate Gas BTU Input for Typical Appliances)

<b>Appliance</b>	<b>Input BTU/h (Approx.)</b>
<b>Space Heating Units</b>	
Warm air furnace	
Single family	100,000
Multifamily, per unit	60,000
<b>Water Heating Appliances</b>	
Water heater, tank type (automatic)	
Storage, 30 to 40 gal.	35,000
Storage, 50 gal.	50,000
<b>Cooking Appliances</b>	
Range, freestanding,	
Domestic	65,000
Build-in oven or broiler unit,	
Domestic	25,000
Built-in top unit,	
Domestic	40,000
<b>Other Appliances</b>	
Refrigerator	3,000
Clothes dryer (residential)	35,000
Gas fireplace (direct vent)	40,000
Gas log	80,000
Barbecue	40,000
Gaslight	2,500

Table 12-8 Schedule 40 Metallic Pipe [NFPA Table]											Gas: Natural			
											Inlet Pressure Specific	Less than 2 psi 0.5 in. w.c. 0.60		
Nominal Actual Length(ft)	Pipe Size (in.)													
	½	¾	1	1¼	1½	2	2½	3	4	5	6	8	10	12
	Capacity in Cubic Feet of Gas per Hour													
10	172	360	678	1,39	2,09	4,02	6,40	11,30	23,10	41,80	67,60	139,00	252,00	399,00
20	118	247	466	95	1,43	2,76	4,40	7,78	15,90	28,70	46,50	95,50	173,00	275,00
30	95	199	374	76	1,15	2,22	3,53	6,25	12,70	23,00	37,30	76,70	139,00	220,00
40	81	170	320	65	98	1,90	3,02	5,35	10,90	19,70	31,90	65,60	119,00	189,00
50	72	151	284	58	87	1,68	2,68	4,74	9,66	17,50	28,30	58,20	106,00	167,00
60	65	137	257	52	79	1,52	2,43	4,29	8,76	15,80	25,60	52,70	95,70	152,00
70	60	126	237	48	72	1,40	2,23	3,95	8,05	14,60	23,60	48,50	88,10	139,00
80	56	117	220	45	67	1,30	2,08	3,67	7,49	13,60	22,00	45,10	81,90	130,00
90	52	110	207	42	63	1,220	1,95	3,45	7,03	12,70	20,60	42,30	76,90	122,00
100	50	104	195	40	60	1,16	1,84	3,26	6,64	12,00	19,50	40,00	72,60	115,00
125	44	92	173	35	53	1,02	1,63	2,89	5,89	10,60	17,20	35,40	64,30	102,00
150	40	83	157	32	48	92	1,48	2,61	5,33	9,65	15,60	32,10	58,30	92,30
175	37	77	144	29	44	85	1,36	2,41	4,91	8,88	14,40	29,50	53,60	84,90
200	34	71	134	27	41	79	1,27	2,24	4,56	8,26	13,40	27,50	49,90	79,00
250	30	63	119	24	36	70	1,12	1,98	4,05	7,32	11,90	24,30	44,20	70,00
300	27	57	108	22	33	63	1,02	1,80	3,67	6,63	10,70	22,10	40,10	63,40
350	25	53	99	20	30	58	93	1,65	3,37	6,10	9,88	20,30	36,90	58,40
400	23	49	92	18	28	54	87	1,54	3,14	5,68	9,19	18,90	34,30	54,30
450	22	46	86	17	26	51	81	1,44	2,94	5,33	8,62	17,70	32,20	50,90
500	21	43	82	16	25	48	77	1,36	2,78	5,03	8,15	16,70	30,40	48,10
550	20	41	78	15	23	45	73	1,29	2,64	4,78	7,74	15,90	28,90	45,70
600	19	39	74	15	22	43	69	1,24	2,52	4,56	7,38	15,20	27,50	43,60
650	18	38	71	14	21	42	66	1,18	2,41	4,36	7,07	14,50	26,40	41,80
700	17	36	68	14	20	40	64	1,14	2,32	4,19	6,79	14,00	25,33	40,10
750	17	35	66	13	20	38	61	1,09	2,23	4,04	6,54	13,40	24,40	38,60
800	16	34	63	13	19	37	59	1,06	2,16	3,90	6,32	13,00	23,60	37,30
850	16	33	61	12	18	36	57	1,02	2,09	3,78	6,11	12,60	22,80	36,10
900	15	32	59	12	18	35	56	992	2,02	3,66	5,93	12,20	22,10	35,00
950	15	31	58	11	17	34	54	963	1,96	3,55	5,76	11,80	21,50	34,00
1,000	14	30	56	11	17	33	53	937	1,91	3,46	5,60	11,50	20,90	33,10
1,100	14	28	53	10	16	31	50	890	1,81	3,28	5,32	10,90	19,80	31,40
1,200	13	27	51	10	15	30	48	849	1,73	3,13	5,07	10,40	18,90	30,00
1,300	12	26	49	10	15	28	46	813	1,66	3,00	4,86	9,98	18,10	28,70
1,400	12	25	47	96	14	27	44	781	1,59	2,88	4,67	9,59	17,40	27,60
1,500	11	24	45	93	13	26	42	752	1,53	2,78	4,50	9,24	16,80	26,60
1,600	11	23	44	89	13	25	41	727	1,48	2,68	4,34	8,92	16,20	25,60
1,700	11	22	42	86	13	25	39	703	1,43	2,59	4,20	8,63	15,70	24,80
1,800	10	22	41	84	12	24	38	682	1,39	2,52	4,07	8,37	15,20	24,10
1,900	10	21	40	81	12	23	37	662	1,35	2,44	3,96	8,13	14,80	23,40
2,000	NA	20	39	79	11	22	36	644	1,31	2,38	3,85	7,91	14,40	22,70

NA means a flow of less than 10 cfh.

Note: All table entries are rounded to 3 significant digits.